

SPECIFICATION & FEATURES

DESCRIPTION:

Orbit Industries' Form 7 threaded conduit bodies used with Rigid/IMC conduits and serve as pulling fittings that make bends and connect conduit runs in conduit system. Flat back design and cubic internal volume ensure a neat and compact installation while providing access for splicing, pulling, maintenance.
Trade Size from 1/2" To 3"

CERTIFICATION:

UL file E227970, conforms to UL 514A

GRAY IRON FORM 7 THREADED CONDUIT BODIES "C" SERIES 1/2" TO 3"



FEATURES:

- Sand cast class 30 gray iron alloy
- Zinc electroplated for added corrosion protection
- Flat back design for maximum internal wiring volume
- Interchangeable with other Form 7 conduit bodies
- Suitable for wet location when used with gasket and cover
- Use with easy clip-on covers
- NPT Thread Hubs

LINE DRAWINGS:

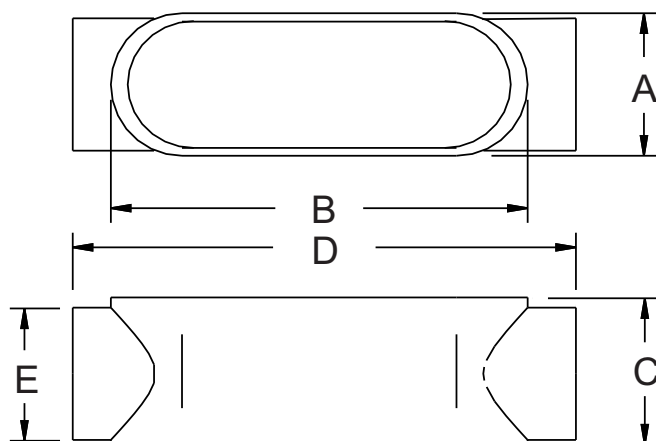

CONFIGURATION DATA:

Part No.	Trade Size	A (in)	B (in)	C (in)	D (in)	E (in)	Max. no. of conductors	Volumn (Cu. In.)	Std. Pkg.
C7-50	1/2"	1-3/8"	3-11/16"	1-3/8"	5-5/16"	1-1/4"	-	4	10
C7-75	3/4"	1-5/8"	4-5/16"	1-5/8"	6-3/16"	1-1/2"	3 #6 AWG	6.6	5
C7-100	1"	1-13/16"	5-1/16"	1-13/16"	7-5/16"	1-13/16"	3 #4 AWG	10.6	5
C7-125	1-1/4"	2-3/16"	5-9/16"	2-3/16"	7-7/16"	2-3/16"	3 #2 AWG	18.8	1
C7-150	1-1/2"	2-7/16"	6-1/16"	2-7/16"	8-3/16"	2-7/16"	3 #2 AWG	26.4	1
C7-200	2"	3"	7-1/16"	3"	9-1/8"	3"	3 #1/0 AWG	47	1
C7-250	2-1/2"	4-1/4"	9-1/16"	4-1/4"	12-3/8"	3-7/16"	3 #2/0 MCM	95	-
C7-300	3"	4-1/4"	9-1/16"	4-1/4"	12-3/8"	4-1/4"	3 #2/0 MCM	119	-

