

SPECIFICATION & FEATURES

4" SQUARE (4S) WELDED BOXES 1-1/2" DEEP WITH NM

DESCRIPTION:

Orbit Industries' 4" Square (4S) Boxes are used to install lighting fixtures, switches, and receptacles in ceilings and walls. They are constructed from 16 gauge galvanized steel. The 1-1/2" deep, welded boxes include non-metallic sheathed cable clamps for ease of installation. Selected models include metal stud brackets that engage on either side of a metal stud or a bracket to directly mount on a stud.

CERTIFICATION:

UL file E227970, conforms to UL514A.
For Fixture/Luminaire Support of 50 lbs or less (Except 4SB-NM-MS)

FEATURES

Knockout:

50: 1/2" K.O. ; **Loom:** Loom Pryouts ;
MKO: Moon K.O. (1/2" and 3/4" K.O.)

Bracket:

FB: (L: 7-3/8", W: 1-9/16") Offset (Flush) Mounts on flat side of stud
WB: (L: 7-1/2", W: 1-9/16") Offset (Flush) With positioning spurs to mount box on side of stud
MS: (L: 2-1/2", W: 1-3/8") Offset (Flush) Self-Gripping Metal Stud Bracket with Box Support Clip. Engages on either side of metal stud.
U.S. Patent No.: 8,262,043

Clamp:

NM: Accommodates #14-2 to #10-3 Non-Metallic Cables with ground

Mfg. Process:

WELDED

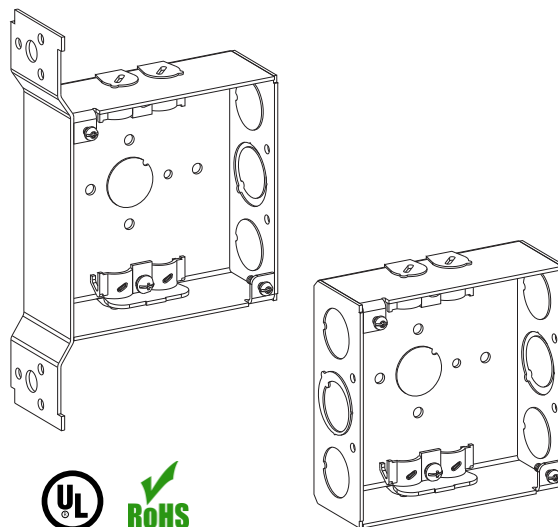

DIMENSIONS

Width: 4"
Height: 4"
Depth: 1-1/2"
Cu.In.: 21.0

CONFIGURATION DATA

Catalog No.	Bracket & Setback	Knockouts		Std. Pkg.
		Sides	Bottom	
4SB-NM	-	(4)-1/2", (2)-MKO, (4)-Loom	(1)-1/2"	50
4SB-NM-FB	FB, Flush	(2)-1/2", (1)-MKO, (4)-Loom	(1)-1/2"	24
4SB-NM-MS*	MS, Self-Gripping+Box Support Clip	(2)-1/2", (1)-MKO, (4)-Loom	(1)-1/2"	24
4SB-NM-WB	WB, Flush	(2)-1/2", (1)-MKO, (4)-Loom	(1)-1/2"	24

* While Supplies Last

