

SPECIFICATION & FEATURES

4" OCTAGON (40) WELDED DEEP BOXES 2-1/8" DEEP WITH NM

DESCRIPTION:

Orbit Industries' 4" Octagon (40) Welded Boxes are used in the installation of light fixtures, and other electrical devices. They are constructed from 16 gauge galvanized steel. The 2-1/8" deep, welded boxes provide extra space for wires and devices, and non-metallic sheathed cable clamp is included for ease of installation. Selected models include an FB Bracket for direct mounts on studs or an LB bracket with spurs.

CERTIFICATION:

UL file E227970, conforms to UL514A.
For Fixture/Luminaire Support of 50 lbs or less

FEATURES

Knockout:

50: 1/2" K.O.

Loom: Loom Pryouts

MKO: Moon K.O. (1/2" and 3/4" K.O.)

Bracket:

FB: (L: 7-1/4", W: 3/4") Offset (1/2") Mounts on flat side of stud or joist

LB: (L: 2-3/8", W: 2-23/32") Offset (1/4") With spurs, slotted holes for toe-nailing.

Clamp:

NM: Accommodates #14-2 to #10-3 Non-Metallic Cables with ground

Mfg. Process:

WELDED

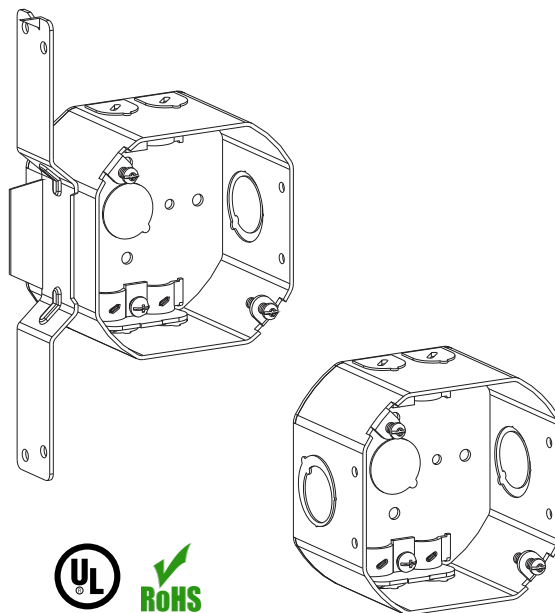

DIMENSIONS

Diameter: 4"

Depth: 2-1/8"

Cu.In.: 21.5

CONFIGURATION DATA

Catalog No.	Bracket & Setback	Knockouts		Std. Pkg.
		Sides	Bottom	
4RDB-NM	-	(2)-MKO, (4)-Loom	(1)-1/2"	50
4RDB-NM-FB	FB, 1/2"	(1)-MKO, (4)-Loom	(1)-1/2"	25
4RDB-NM-LB	LB, 1/2"	(2)-MKO, (4)-Loom	(1)-1/2"	25

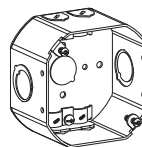

4RDB-NM

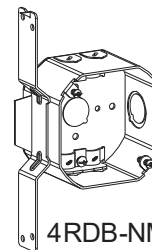

4RDB-NM-FB

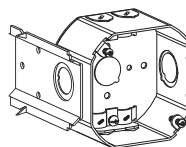

4RDB-NM-LB

