

SPECIFICATION & FEATURES

DESCRIPTION:

Orbit Industries' 4" Octagon (40) Welded Boxes are used in the installation of light fixtures and other electrical devices in walls and ceilings. They are constructed from 16 gauge galvanized steel. The 1-1/2" deep, welded boxes include Metal Clad Clamps for ease of installation. Selected models include a bracket or bar hanger for a range of applications.

CERTIFICATION:

UL file E227970, conforms to UL514A.

For Fixture/Luminaire Support of 50 lbs or less

(For all boxes and 4RB-MC-BHA at 16" span, except 4RB-MC-E)

FEATURES

Knockout:

50: 1/2" K.O.

Loom: Loom Pryouts

Bracket:

FB: (L: 7-1/4", W: 3/4") Offset (1/2") Mounts on flat side of stud or joist

E: Ears

Bar Hanger:

BHAC: Adjustable Bar Hanger allows installation of box anywhere along length of stud. Cables with ground

BX/MC Clamp:

Accommodates Metal Clad Cables from size #14-2 to #10-4.

All MC series boxes are suitable for use with MCAP™-Aluminum (MCAP is a trademark of Southwire Company)

Mfg. Process:

WELDED

4" OCTAGON (40) WELDED BOXES 1-1/2" DEEP WITH BX/MC

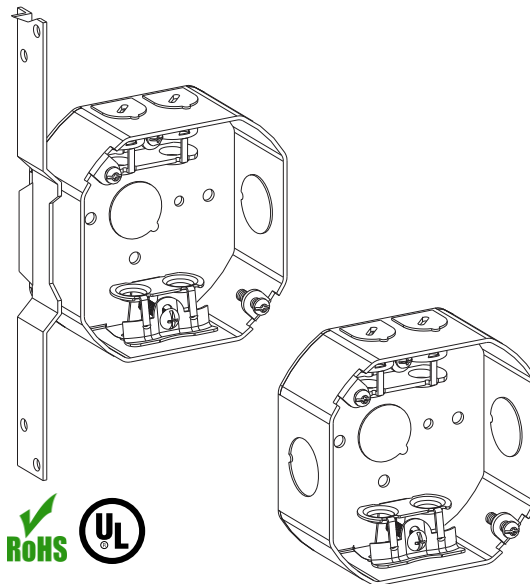

DIMENSIONS

Diameter: 4"

Depth: 1-1/2"

Cu.In.: 15.5

CONFIGURATION DATA

Catalog No.	Bracket & Setback	Knockouts		Std. Pkg.
		Sides	Bottom	
4RB-MC	-	(2)-1/2", (4)-Loom	(1)-1/2"	50
4RB-MC-E	Ears	(2)-1/2", (4)-Loom	(1)-1/2"	50
4RB-MC-FB	FB, 1/2"	(1)-1/2", (4)-Loom	(1)-1/2"	50
4RB-MC-BHAC	Adjustable from 16" to 24"	(2)-1/2", (4)-Loom	-	25

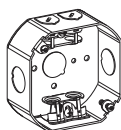

4RB-MC

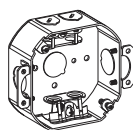

4RB-MC-E

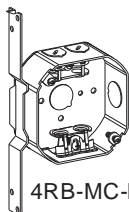

4RB-MC-FB

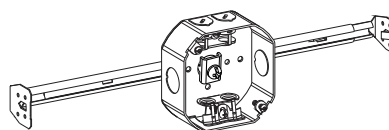

4RB-MC-BHAC

