

SPECIFICATION & FEATURES

DESCRIPTION:

Orbit Industries' 4" Octagon (40) Welded Boxes are used in the installation of light fixtures and other electrical devices in walls and ceilings. They are constructed from 16 gauge galvanized steel. The 1-1/2" deep boxes include non-metallic sheathed cable clamps allow for easy installation. Selected models include a bracket or ears for a range of applications.

CERTIFICATION:

UL file E227970, conforms to UL514A.
 For Fixture/Luminaire Support of 50 lbs or less
 (For all boxes and 4RB-NM-BHA at 16" span, except 4RB-NM-E and 4RB-NM-SG)

FEATURES

Knockout:

50: 1/2" K.O.

Loom: Loom Pryouts

Bracket:

FB: (L: 7-1/4", W: 3/4") Offset (1/2") Mounts on flat side of stud or joist

LB: (L: 2-3/8", W: 2-23/32") With spurs, slotted holes for toe-nailing

SG: Swing Bracket, Old Work

E: Ears

Bar Hanger:

BHA: Adjustable Bar Hanger allows installation of box anywhere along length of stud. Cables with ground

Mfg. Process:

WELDED

4" OCTAGON (40) WELDED BOXES 1-1/2" DEEP WITH NM

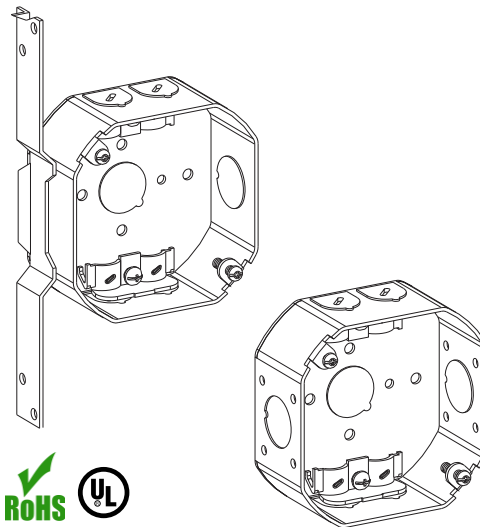

DIMENSIONS

Diameter: 4"

Depth: 1-1/2"

Cu.In.: 15.5

CONFIGURATION DATA

Catalog No.	Bracket & Setback	Knockouts		Std. Pkg.
		Sides	Bottom	
4RB-NM	-	(2)-1/2", (4)-Loom	(1)-1/2"	50
4RB-NM-E	Ears	(2)-1/2", (4)-Loom	(1)-1/2"	50
4RB-NM-FB	FB, 1/2"	(1)-1/2", (4)-Loom	(1)-1/2"	50
4RB-NM-LB	LB, Flush	(2)-1/2", (4)-Loom	(1)-1/2"	50
4RB-NM-SG	Swing Bracket, Old Work	(4)-Loom	(1)-1/2"	50
4RB-NM-BHA	Adjustable from 16" to 24"	(2)-1/2", (4)-Loom	-	25

