

## SPECIFICATION & FEATURES

## 4" OCTAGONAL CONCRETE BOXES

### DESCRIPTION:

Orbit Industries' 4" Octagonal Concrete Boxes are used for concrete constructions. The 1/2", 3/4", 1" side knockouts and mounting tabs allow for easy installation. They are constructed from 16 gauge galvanized steel. Orbit Industries' selection includes concrete rings with depths ranging from 2" to 6".

### CERTIFICATION:

UL file E227970, conforms to UL514A.  
For Fixture/Luminaire Support of 50 lbs or less

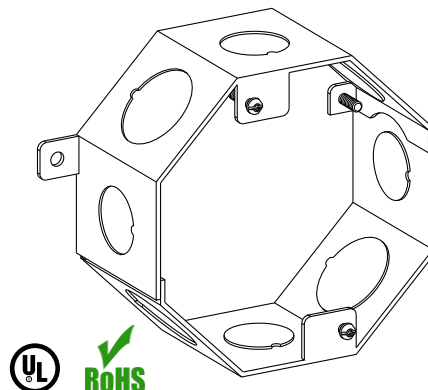

### FEATURES

#### Knockout:

50: 1/2" K.O. 75: 3/4" K.O. 100: 1" K.O.

4CB-F is UL Rated for Fan Support of 35 LBS or Less; For Fixture/Luminaire Support of 90 LBS or Less

Other Concrete boxes are UL Rated for Fixture/Luminaire Support of 50 LBS or Less

### DIMENSIONS

Diameter: 4"

Other Dimensions see below

### CONFIGURATION DATA

Catalog No.	Depth	Knockouts		Cu.In.	Std. Pkg.
		Sides 1,3,5,7	Sides 2,4,6,8		
2CB	2"	(1)-1/2"	(1)-3/4"	24.4	25
25CB	2-1/2"	(1)-1/2"	(1)-3/4"	30.5	25
3CB	3"	(1)-1/2"	(1)-3/4"	37.0	25
3CB-75/100	3"	(1)-3/4"	(1)-1"	37.0	25
35CB	3-1/2"	(2)-1/2"	(2)-3/4"	43.0	25
35CB-75/100	3-1/2"	(1)-3/4"	(1)-1"	43.0	25
4CB	4"	(2)-1/2"	(2)-3/4"	49.2	25
4CB-75/100	4"	(2)-3/4"	(2)-1"	49.2	25
4CB-F*	4"	Side 1, 5: (1)-1/2" Side 3, 7: (2)-1/2"	Side 2, 6: (1)-3/4" Side 4, 8: (2)-3/4"	49.2	25
5CB	5"	(2)-1/2"	(2)-3/4"	61.7	10
6CB	6"	(2)-1/2"	(2)-3/4"	73.5	10

\*Fan Rated

