

SPECIFICATION & FEATURES

DESCRIPTION:

Orbit Industries' 4" Square (4S) Deep Boxes are used to install lighting fixtures, switches, and receptacles in ceilings and walls. They are constructed from 16 gauge galvanized steel. These welded, 2-1/8" deep boxes include metal clad cable clamps and knockouts for easy installation. All models include a UMI back support arm to support studs up to 6" deep and a 10" long, solid #12AWG pigtail. Selected models include an adjustable ring. They are great for pre-fab applications.

CERTIFICATION:

UL file E227970, conforms to UL514A.
For Fixture/Luminaire Support of 50 lbs or less

FEATURES

Pigtail Features:

PT: 10" Solid Cu. #12AWG Pigtail Pre-assembled with Ground Emboss and 10-32 Ground Screw

Knockout:

50: 1/2" K.O.; **75:** 3/4" K.O.; **MKO:** Moon K.O. (1/2" and 3/4" K.O.)

Bracket:

AB: 90° (L: 5-7/8", W: 7/8") Offset (Flush) Positions box against face and side of stud

Back Support:

BSA: UMI Back Support Arm installed on this box provides support for studs up to 6" deep

Mfg. Process:

WELDED

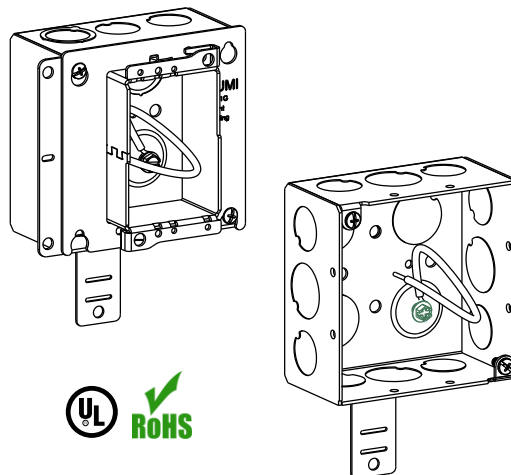

DIMENSIONS

Width: 4"
Height: 4"
Depth: 2-1/8"
Cu.In.: 30.3

CONFIGURATION DATA

Catalog No.	Bracket & Setback	Knockouts		Std. Pkg.
		Sides	Bottom	
4SDB-50/75-PT-BSA	With Back Support Arm	(8)-1/2", (4)-3/4"	(1)-1/2", (2)-3/4"	24
4SDB-50/75-AB-PT-BSA	With AB, Flush, Back Support Arm	(6)-1/2", (3)-3/4"	(1)-1/2", (2)-3/4"	24
4SDB-MKO-PT-BSA	With Back Support Arm	(8)-1/2", (4)-MKO	(1)-1/2", (2)-MKO	24
4SDB-MKO-AB-PT-BSA	With AB, Flush, Back Support Arm	(6)-1/2", (3)-MKO	(1)-1/2", (2)-MKO	24
4SDB-MKO-AR1G	AB, Flush, Back Support Arm w/ 4SA1RG	(6)-1/2", (3)-MKO	(1)-1/2", (2)-MKO	24
4SDB-MKO-AR2G	AB, Flush, Back Support Arm w/ 4SA2RG	(6)-1/2", (3)-MKO	(1)-1/2", (2)-MKO	24

