

# Emergency Lights

## EMERGENCY LIGHT

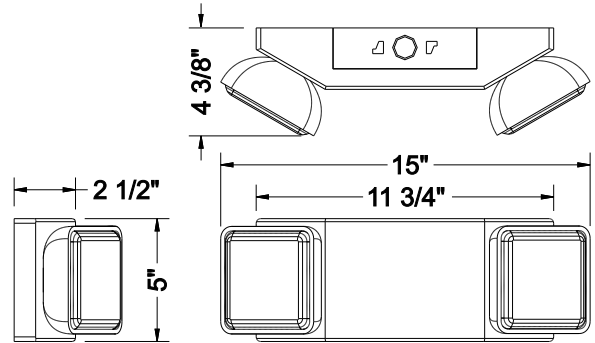

EL2N



- Listed for Damp Location
- 120/277 VAC with Universal Transformer
- Two 5.4W Wedge base Lamps
- 90 minutes Emergency Operation
- 6V, 4.5Ah Lead-Acid, Maintenance-Free Battery
- Environmentally-Coated Solid State Charger
- Short Circuit and Power Loss Protection
- Push to Test Switch
- Automatic, Low Voltage Disconnect (LVD)
- Charge Rate/Power on LED Indicator Light

- Completely Self-Contained
- Fully Automatic Operation
- Universal Mounting Plate
- Quick-Wire
- Injection-Molded, V-O Flame retardant, high-impact, thermoplastic casing
- Wall or Ceiling Mount



Optional Self Diagnostic/Self Test feature offers the ultimate worry-free maintenance & reliability

Cat. No.	Housing Color	Self-Diagnostic Test
<b>EL2N</b>	W (White) B (Black)	SDT

Quick-Ship Model
<b>EL2N</b>



## MR16 EMERGENCY LIGHT



EL2H

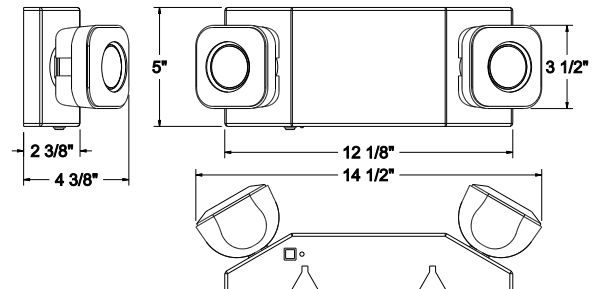

- 120/277 VAC with Universal Transformer
- Two 6V MR16 5W Halogen Lamps
- 90 minutes Emergency Operation
- 6V, 4.5Ah Lead-Acid, Maintenance-Free Battery
- Environmentally-Coated Solid State Charger
- Short Circuit and Power Loss Protection
- Push to Test Switch
- Automatic, Low Voltage Disconnect (LVD)
- Charge Rate/Power on LED Indicator Light

- Completely Self-Contained
- Fully Automatic Operation
- Compact Low Profile Design
- Adjustable Heads
- Universal Mounting Plate
- Quick-Wire
- Injection-Molded, V-O Flame retardant, high-impact, thermoplastic casing
- Wall or Ceiling Mount



Optional Self Diagnostic/Self Test feature offers the ultimate worry-free maintenance & reliability

Cat. No.	Housing Color	Self-Diagnostic Test
<b>EL2H</b>	W (White) B (Black)	SDT

Quick-Ship Model
<b>EL2H</b>



Exit & Emergency