



SUBMITTAL SHEETS

VENTILATION FANS - J



FEATURES & BENEFITS:

Housing Dimensions

- 11-3/8" L x 10-1/2" W x 7-5/8" H

Housing

- Corrosion-Resistant Galvanized Steel
- Adjustable double bar hanger system that extends up to 24"
- Sloped ceiling mounting capability up to 45 degrees
- Includes **detachable 6"** round duct with built-in draft damper
- IC Rated up to R40 insulation

Motor and Blower

- Power rating of 120V/60Hz
- Permanently lubricated, quick installation motor
- Energy efficient, brushless **two speed DC motor** for low speed continuous ventilation from 30-80 CFM
- Built-in dip switch to adjust high fan speed setting from 80 to 140 CFM
- Built-in overload disconnect for safety and longer motor life
- Low RPM for quiet operation
- ETL and cETL listed for tub/shower enclosure when connected to a GFCI protected branch circuit

Grille

- Modern and elegant design
- Durable Polymeric Resin
- Torsion spring clips included for easy mounting

Humidity Sensor

- Adjustable from 50 to 100% relative humidity
- Adjustable timer from 5 to 60 minutes

Warranty

- 2 year limited warranty



ODU814H

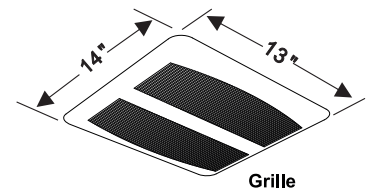
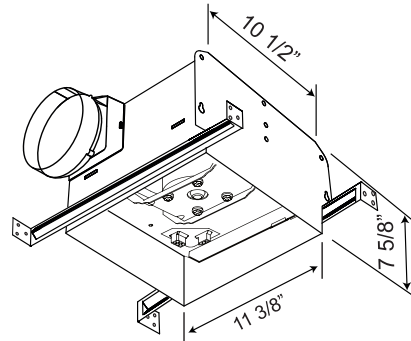

Grille



Cat. No.		ODU814H	
Static pressure	Inches w.g.	0.1"	
Duct diameter	Inches	6"	
Air volume	CFM	90	110
Noise	Sone	0.5	0.9
Power consumption	Watts	9	11
Energy efficiency	CFM/Watts	12.23	11.49
Power rating	V/Hz.	120/60	
Weight	lbs	10.5	
Master Qty.		1	

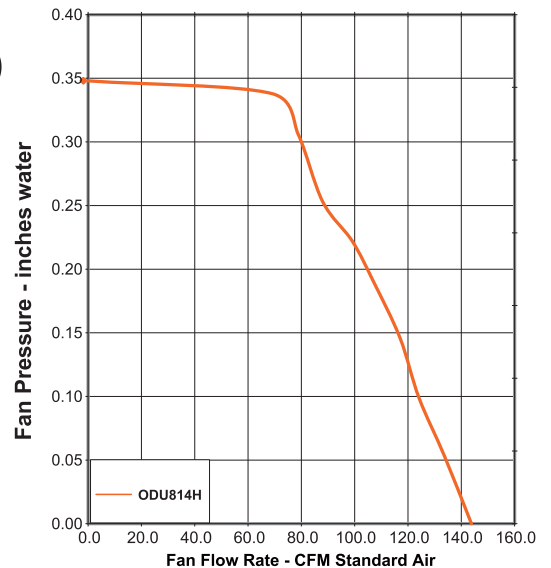

Model #	Quantity	Comments	Project:
			Location:
			Architect:
			Engineer:
			Contractor:
			Submitted by:
			Date:



FEATURES & BENEFITS:

Housing Dimensions

- 11-3/8" L x 10-1/2" W x 7-5/8" H

Housing

- Corrosion-Resistant Galvanized Steel
- Adjustable double bar hanger system that extends up to 24"
- Sloped ceiling mounting capability up to 45 degrees
- Includes **detachable 6"** polymeric collar with lightweight built-in back draft damper
- IC Rated up to R40 insulation

Motor

- Power rating of 120V/60Hz
- Permanently lubricated motor
- Energy efficient, brushless **two speed DC motor** for low speed continuous ventilation from 30-80 CFM
- Quick installation of motor and impeller assembly
- Built-in dip switch to adjust high fan speed setting from 80 to 140 CFM
- Built-in overload disconnect for safety and longer motor life
- Low RPM for quiet operation
- ETL and cETL listed for tub/shower enclosure when used with a GFCI branch circuit

Motion Sensor

- Activates higher motor speed and delayed timer
- Adjustable timer from 5 to 60 minutes

Grille

- Modern and elegant design
- Durable Polymeric Resin
- Torsion clips included for easy mounting

Warranty

- 2 year limited warranty



Grille

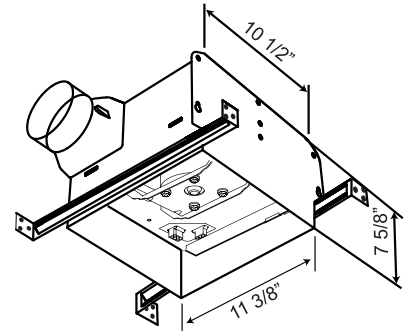
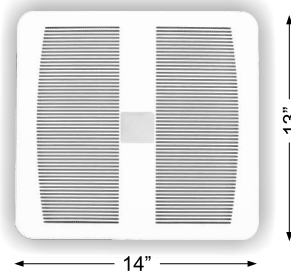

Cat. No.		ODU814M			
Static pressure	Inches w.g.	0.1"			
Duct diameter	Inches	6"			
Air volume	CFM	90	110	120	140
Noise	Sone	0.3	0.6	0.8	1.1
Power consumption	Watts	9	10	10	11
Energy efficiency	CFM/Watts	10	11	12	14
Power rating	V/Hz.	120/60			
Weight	lbs	10.5			

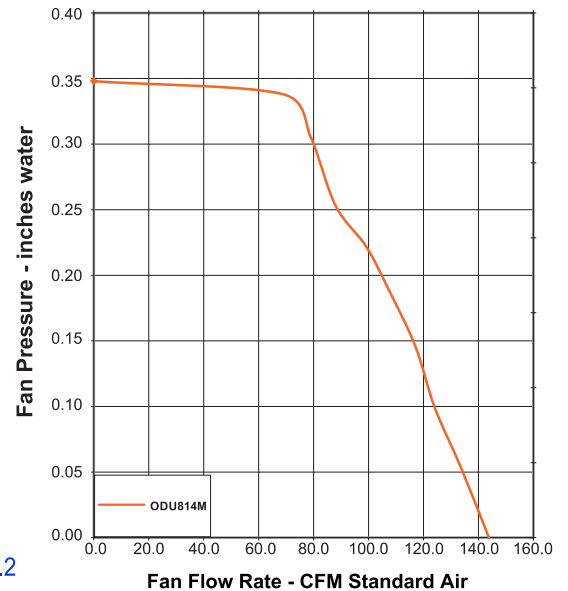

Model #	Quantity	Comments	Project:
			Location:
			Architect:
			Engineer:
			Contractor:
			Submitted by:
			Date:



Heat Fan Light

Model: ODHFL110

FANLIGHTS

FEATURES & BENEFITS:

Housing Dimensions

- 11-3/8" L x 10-1/2" W x 7-5/8" H

Housing

- Corrosion-Resistant Galvanized Steel
- Double hanger bar mounting brackets that are adjustable up to 24"
- Sloped ceiling mounting capability up to 45 degrees
- Includes **detachable 4"** polymeric collar with lightweight built-in back draft damper

Motor

- Power Rating of 120V / 60Hz
- Permanently lubricated, energy efficient motor
- Built-in overload disconnect for safety and longer motor life
- Low RPM for quiet operation
- ETL and cETL listed for tub/shower enclosure when used with a GFCI branch circuit

Heater

- 1000W PTC ceramic heater with metal blower
- Thermal auto-self protection
- Electric shock protection

Grille

- Thermal paint 22 gauge sheet metal
- Torsion spring clips included for easy mounting

Warranty

- 2 year limited warranty

Lighting

FANLIGHTS

Not Included:
2 - 23 Watt GU24 Compact
Fluorescent Lamp

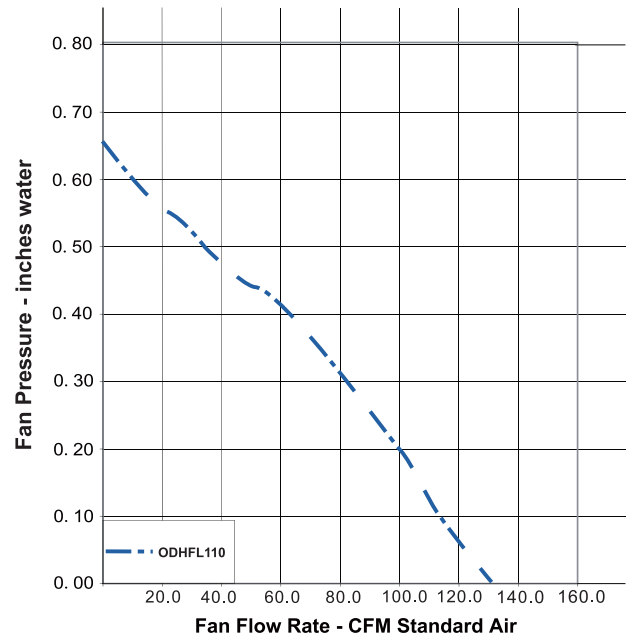
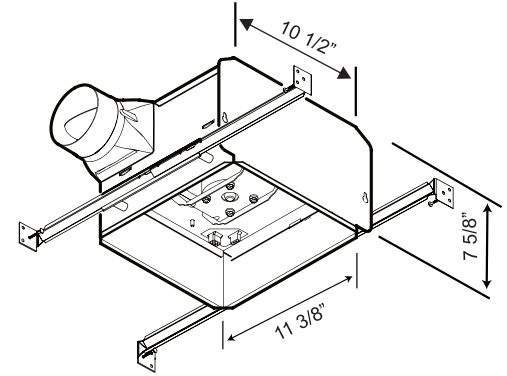
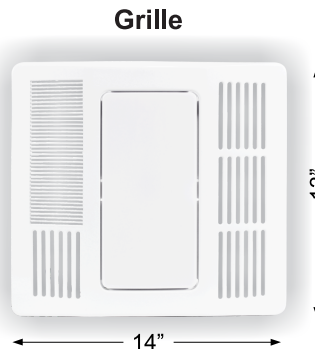

Cat. No.	ODHFL110	
Static pressure	Inches w.g.	0.1"
Duct diameter	Inches	4"
Air volume	CFM	110
Noise	Sone	0.9
Power consumption	Watts	9
Energy efficiency	CFM/Watts	8.9
Power rating	V/Hz.	120/60

Model #	Quantity	Comments	Project:
			Location:
			Architect:
			Engineer:
			Contractor:
			Submitted by:
			Date:



FEATURES & BENEFITS:

Housing Dimensions

- 9-1/8" L x 9-1/8" W x 7-5/8" H

Housing

- Heavy-duty steel housing coated with rust proof paint
- Adjustable double bar hanger system that extends up to 24"
- 4" exhaust pipe connection
- Wired for both fan or fanlight
- Effortless side electrical connection
- Termination damper to prevent cold air infiltration
- Light, durable, and sturdy

Motor and Blower

- Power rating of 120V/60Hz
- Permanently lubricated, energy efficient motor with ball bearings designed for continuous use
- Quick installation of motor and impeller assembly
- Effortless snap in wiring connection
- UL and cUL listed for tub/shower enclosure when connected to a GFCI protected branch circuit

Grille

- Contemporary design - with or without light kit
- Durable white ABS for easy cleaning
- Torsion spring clips included for easy installation
- Electronic ballast

Lighting



FANLIGHTS

Included: 2 - 18 Watt Flicker-Free, Electronic Ballast Compact Fluorescent Lamps

Warranty

- 2 year limited warranty



Fanlights Model

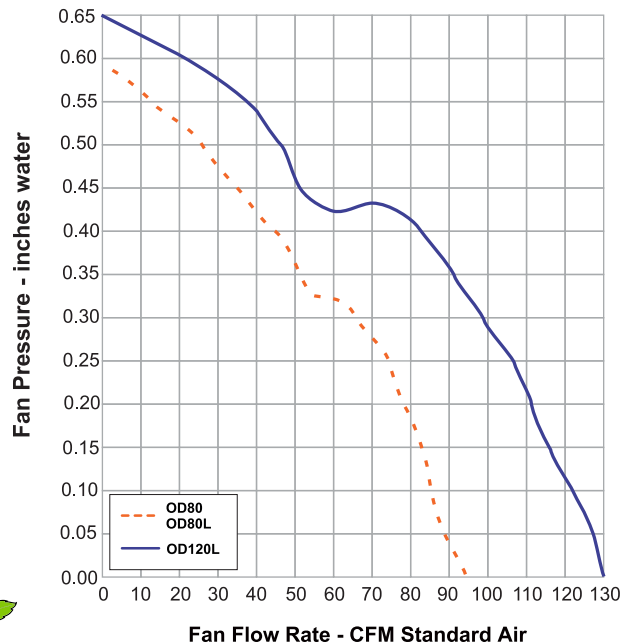

		FANS	FANLIGHTS
Model		OD80	OD120L
Cat. No.		OD80	OD120L
Static pressure	Inches w.g.	0.1"	0.1"
Air volume	CFM	80	120
Noise	Sone	0.8	1.5
Power consumption	Watts	27.9	37.0
Energy efficiency	CFM/Watts	2.87	3.24
Speed	RPM	946	1,201
Current	Amps	.18	.30
Power rating	V/Hz.	120/60	120/60
Duct diameter	Inches	4"	4"
Motor type		Enclosed	Enclosed
Weight	lbs	10	10
Master Qty.		4	4

Model #	Quantity	Comments	Project:
			Location:
			Architect:
			Engineer:
			Contractor:
			Submitted by:
			Date:



FEATURES & BENEFITS:

Housing Dimensions

- 9-1/8" L x 9-1/8" W x 7-5/8" H

Housing

- Heavy-duty steel housing coated with rust proof paint
- Adjustable double bar hanger system that extends up to 24"
- 4" exhaust pipe connection
- Wired for both fan or fanlight
- Effortless side electrical connection
- Termination damper to prevent cold air infiltration
- Light, durable, and sturdy

Motor and Blower

- Power rating of 120V/60Hz
- Permanently lubricated, energy efficient motor with ball bearings designed for continuous use
- Quick installation of motor and impeller assembly
- Effortless snap in wiring connection
- UL and cUL listed for tub/shower enclosure when connected to a GFCI protected branch circuit

Grille

- Contemporary design - with or without light kit
- Durable white ABS for easy cleaning
- Torsion spring clips included for easy installation
- Electronic ballast

Lighting



FANLIGHTS

Included: 2 - 18 Watt Flicker-Free, Electronic Ballast Compact Fluorescent Lamps

Warranty

- 2 year limited warranty



Fanlights Model

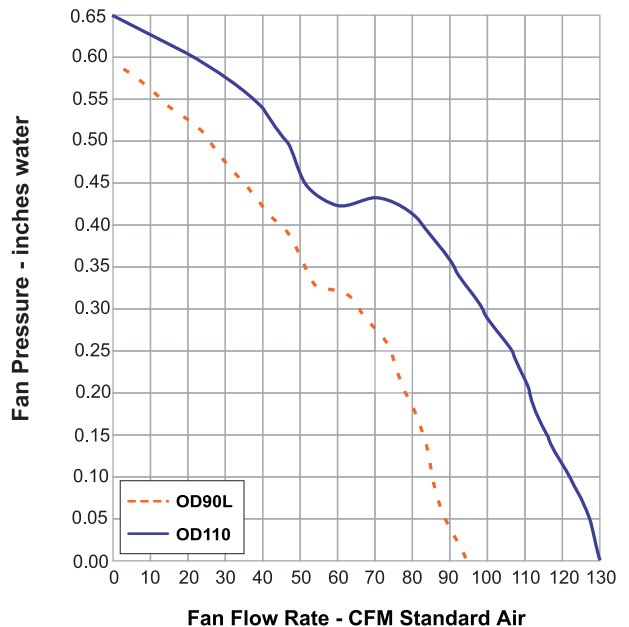

Model		FANS	FANLIGHTS
Cat. No.		OD110*	OD90L
Static pressure	Inches w.g.	0.1"	0.1"
Air volume	CFM	110	90
Noise	Sone	1.5	0.7
Power consumption	Watts	30.6	32.1
Energy efficiency	CFM/Watts	3.59	2.80
Speed	RPM	1,083	1,017
Current	Amps	.19	.26
Power rating	V/Hz.	120/60	120/60
Duct diameter	Inches	4"	4"
Motor type		Enclosed	Enclosed
Weight	lbs	10	10
Master Qty.		4	4



Model #	Quantity	Comments	Project:
			Location:
			Architect:
			Engineer:
			Contractor:
			Submitted by:
			Date:



FEATURES & BENEFITS:

Housing Dimensions

- 9-1/8" L x 9-1/8" W x 7-5/8" H

Housing

- Heavy-duty steel housing coated with rust proof paint
- Adjustable double bar hanger system that extends up to 24"
- Includes 4" exhaust pipe connection
- Wired for both fan only or fanlight
- Effortless side electrical connection
- Termination damper to prevent cold air infiltration
- Light, durable and sturdy

Motor and Blower

- Power rating of 120V/60Hz
- Permanently lubricated, energy efficient motor designed to continuously active
- Quick installation of motor and impeller assembly
- Effortless snap in wiring connection
- UL and cUL listed for tub/shower enclosure when connected to a GFCI protected branch circuit

Grille

- Contemporary design - with or without light kit
- Durable white ABS for easy cleaning
- Torsion spring clips included for easy mounting
- Electronic ballast

Warranty

- 2 year limited warranty

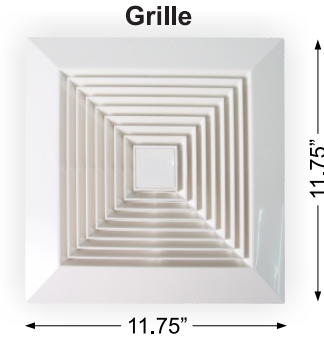

Model		FANS	
Cat. No.	Inches w.g.	OEP90*	OEP110
Static pressure	Inches w.g.	0.1"	0.1"
Air volume	CFM	90	110
Noise	Sone	1.5	2.0
Power consumption	Watts	24.5	27
Energy efficiency	CFM/Watts	3.67	4.07
Speed	RPM	1,227	1,393
Current	Amps	.21	.16
Power rating	V/Hz.	120/60	120/60
Duct diameter	Inches	4"	4"
Motor type		Enclosed	Enclosed
Weight	lbs	9.9	9.9
Master Qty.		4	4



TITLE 24 COMPLIANT

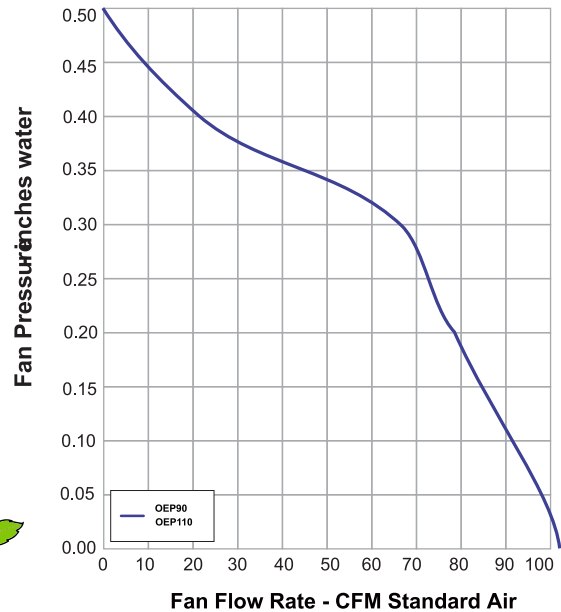

Model #	Quantity	Comments	Project:
			Location:
			Architect:
			Engineer:
			Contractor:
			Submitted by:
			Date: